



MURPHY[®]

by **EMOVATION** CONTROLS

POWERCORE[®] TEC-10

SUPERIOR TURNKEY PANEL OFFERS COMPLETE CONTROL, FAMILIARITY ACROSS APPLICATIONS



Supports SAE J1939 CAN protocols

Change settings from the face of the panel

Rugged panel withstands dust, water and vibration

Can be utilized across many applications providing familiarity for users



Murphy's PowerCore[®] TEC-10 panel provides full control of your engine including auto start/stop, auto throttling and display of engine parameters along with critical faults from the engine/application. The TEC-10 supports SAE J1939 CAN protocols for electronically governed engines as well as analog sensors on mechanical engines for fault and safety warnings/shutdowns.

An incredibly versatile control panel, the TEC-10 allows parameters and settings to be changed directly from the front face or via a free PC configuration tool. Powerful flexibility allows for the same control panel to be used across a wide range of applications while providing operator consistency and familiarity.

The control panel features molded-in industry-standard connectors mating with Deutsch HDP series connectors and is compatible for use on the simplest mechanical

engine to the most advanced, fully electronic Tier 4 engines.*

Designed as a plug-and-play solution, the TEC-10 panel is perfect for rental or industrial applications where I/O is needed and auto start or auto throttling is desired.

The rugged TEC-10 panel can be mounted directly to the engine or engine/application cover. Built to endure industrial environments from full sun to wide temperature ranges, the panel features a high degree of sealing for dust and water as well as the ability to withstand higher vibration with exposure.

*Murphy Industrial Harness or John Deere OEM engine harnessing required.

POWERCORE® TEC-10 PANEL

Standard Dimensions

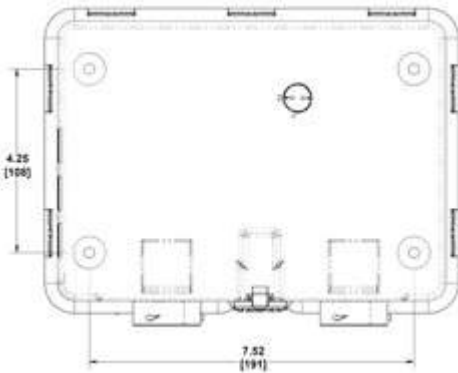
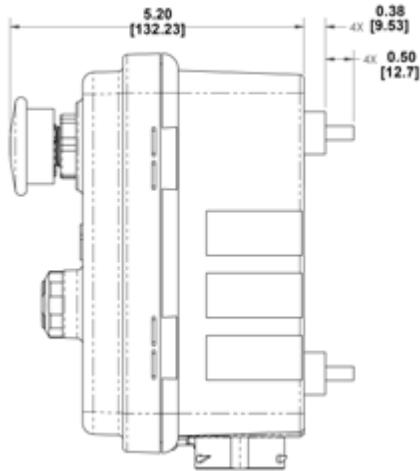
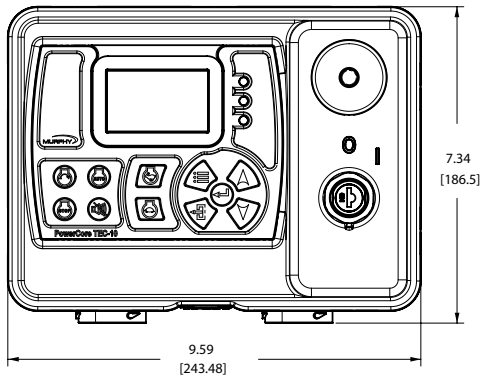

TEC-10 PANEL SPECIFICATIONS

• Interface

Display:

Monochrome HR-TFT

2.7 in./ 68 mm, WQVGA (400 x 240 pixels)

Languages: English, Spanish, German, French, Italian

(3) LEDs: green (mode), yellow (warning) and red (shutdown)

Operator controls:

(11) Raised silicone keypads, tactile feedback

(1) Rotary switch, power on/off

(1) Push-switch (red), engine stop

• Power Supply:

Operating Voltage: 8-32 VDC, reverse battery polarity and load dump protected

Cranking Power Holdup: 0 VDC up to 50 mS(also good for brownout/blackout instances)

Current consumption: Power on in stopped state; 117 mA at 12 VDC. Power

on in standby mode; 52 mA at 12 VDC.

• Inputs (9):

(5) Digital, configurable (active on High, Low, Open)

(3) Analog, configurable (4-20 mA, 0-5V, resistive or digital ground)

(1) Frequency, supporting:

Magnetic pickup (30 Hz - 10 kHz, 2.0 VAC-120 VAC) and Engine

Alternator (30 Hz - 10 kHz, 4.5 VRMS - 90 VRMS)

• Outputs (8):

(2) Relay, switched +DC, 10A

(1) Relay, Form C (dry / volt-free), 10A

(2) Low-side FET (-DC), 1A

(2) High-side FET (+DC), 1A

(1) Dedicated Alternator Excitation, +DC, 1A

• Communications:

(1) CAN: J1939

(1) RS485: Modbus RTU

• Mating Connectors:

21 Position, Deutsch HDP26-24-21SE,

31 Position, Deutsch HDP26-24-31SE

• Physical/Environmental:

Enclosure material: Polycarbonate

Dimensions (WxHxD): 9.59 x 7.34 x 5.20 in. (243.48 x 186.5 x 132.23mm)

Weight: 4 lbs (1.8 kg)

IP rating: IP67

Operating Temperature: -40° to +85° C (-40° to 185° F)

Storage Temperature: -40 to +85° C (-40° to 185° F)

Vibration: 7.86 Grms (5-2000 Hz), 3-axis random

Shock: ±50G, 3-axis

ENOVATION CONTROLS CORPORATE HEADQUARTERS
5311 S 122ND EAST AVENUE
TULSA, OK 74146

ENOVATION CONTROLS LTD. – UNITED KINGDOM
CHURCH ROAD LAVERSTOCK
SALISBURY SP1 1QZ UK

MURPHY INTERNATIONAL TRADING – CHINA
SUITE 1704, ANTAI BUILDING, 107 ZUNYI RD
SHANGHAI, 2000 S1 CHINA

ENOVATION CONTROLS INDIA PVT. LTD.
301, 3RD FLOOR, KRSNA CHAMBERS 11,
GALAXY GARDENS, NORTH MAIN ROAD,
KOREGAON PARK, PUNE - 411001
MAHARASHTRA, INDIA

U.S. SALES & SUPPORT

MURPHY PRODUCTS
PHONE: 918 317 4100
EMAIL: SALES@ENOVATIONCONTROLS.COM
WWW.ENOVATIONCONTROLS.COM

MURPHY INDUSTRIAL PANEL DIVISION
PHONE: 918 317 4100
EMAIL: IPDSALES@ENOVATIONCONTROLS.COM

INTERNATIONAL SALES & SUPPORT

EUROPE, MIDDLE EAST, AFRICA
PHONE: +44 1722 410055
EMAIL: SALES@ENOVATIONCONTROLS.EU

CHINA
PHONE: +86 21 6237 5885
EMAIL: APSALES@ENOVATIONCONTROLS.COM

LATIN AMERICA & CARIBBEAN
PHONE: +1 918 317 2500
EMAIL: LASALES@ENOVATIONCONTROLS.COM

INDIA
PHONE: +91 91581 37633
EMAIL: INDIASALES@ENOVATIONCONTROLS.COM



FM 28221 (Tulsa, OK - USA)
FM 29422 (UK)